

Team Members

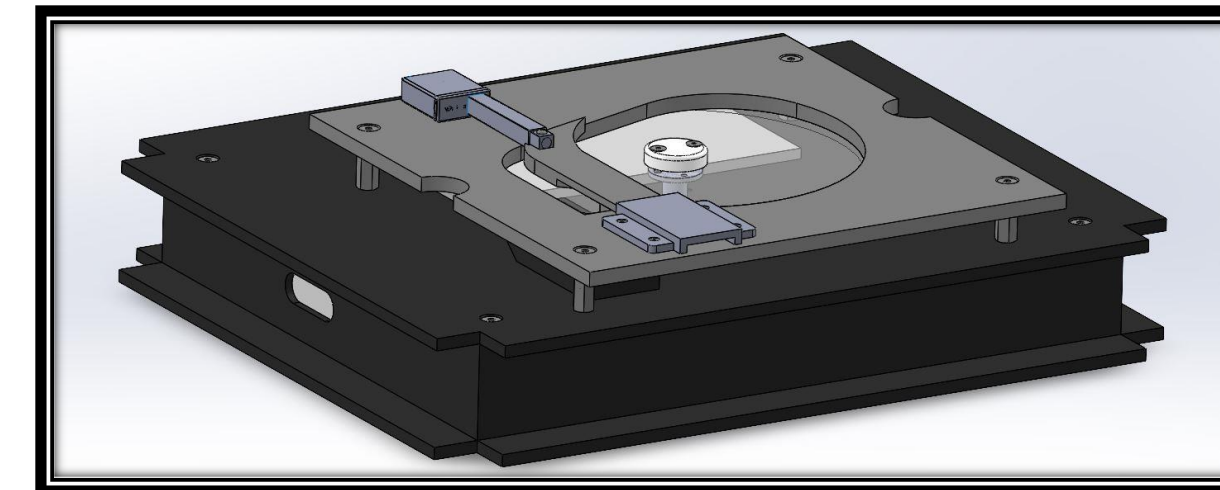

Sub-Assemblies



Counting Subsystem

The stepper motor rotates the disc creating centrifugal force on the pills. This force along with the counting arm forces the pills through a channel which houses an infrared sensor. The sensor counts the pills passing and relays this information to the microcontroller. Once the required number of pills have passed the sensor, the motor stops. The counted pills drop from this subsystem through a funnel into the Delivery Subsystem.

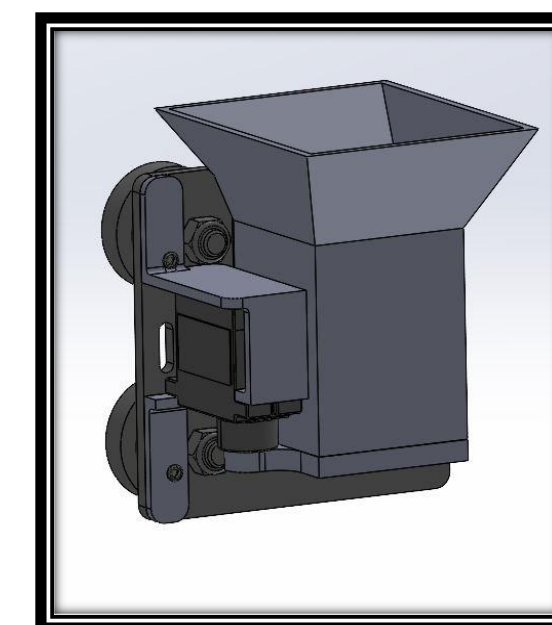

Delivery Subsystem

The Delivery Subsystem consists of a funnel which rides on a gantry cart and linear slide controlled by a motor. The counted pills enter the funnel, and the motor activates to move the funnel to the appropriate day. Once the motor has arrived, the servo rotates the flap open. The pills then fall into the Verification System. The funnel then returns to its starting position to collect the next day's dose.

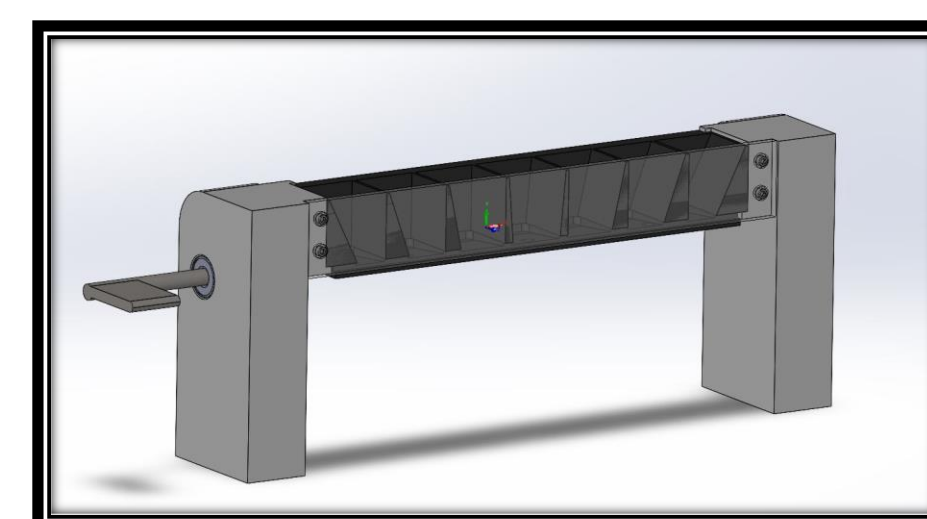

Verification Subsystem

Once the Delivery Subsystem has delivered all the pills for the week, the user will be prompted to verify the dosage. This is accomplished by looking through the clear acrylic and certifying that the pill dosage is correct. The user is then required to rotate the handle, allowing the pills to drop into the user's personal daily pill organizer.

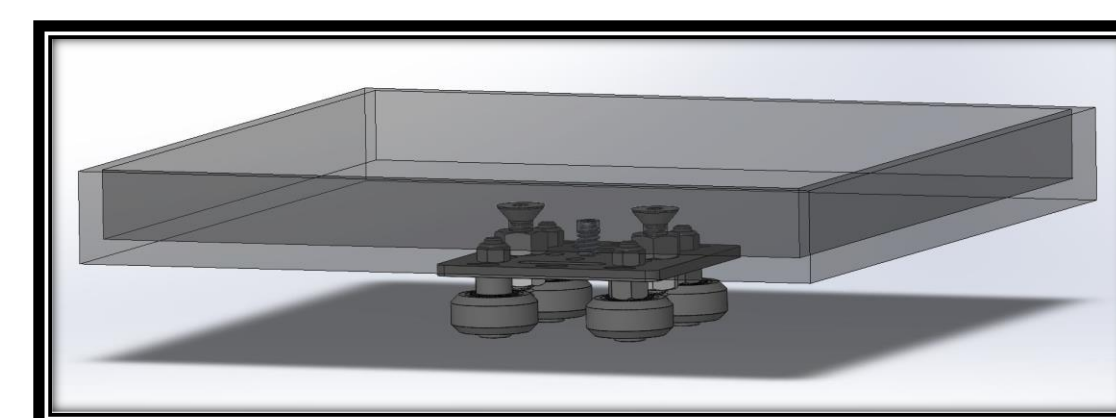

Slider Subsystem

The Slider Subsystem is responsible for ensuring that the Verification Subsystem can accurately drop multiple weeks' worth of doses into the personal pill organizer. The Slider Subassembly is a monthly organizer tray placed on a gantry cart riding on a linear rail. The gantry cart is fitted with a ball plunger and the linear rail has notches which will provide tactile feedback to the user when the tray is seated into the correct position.

CAD Design – Exploded View

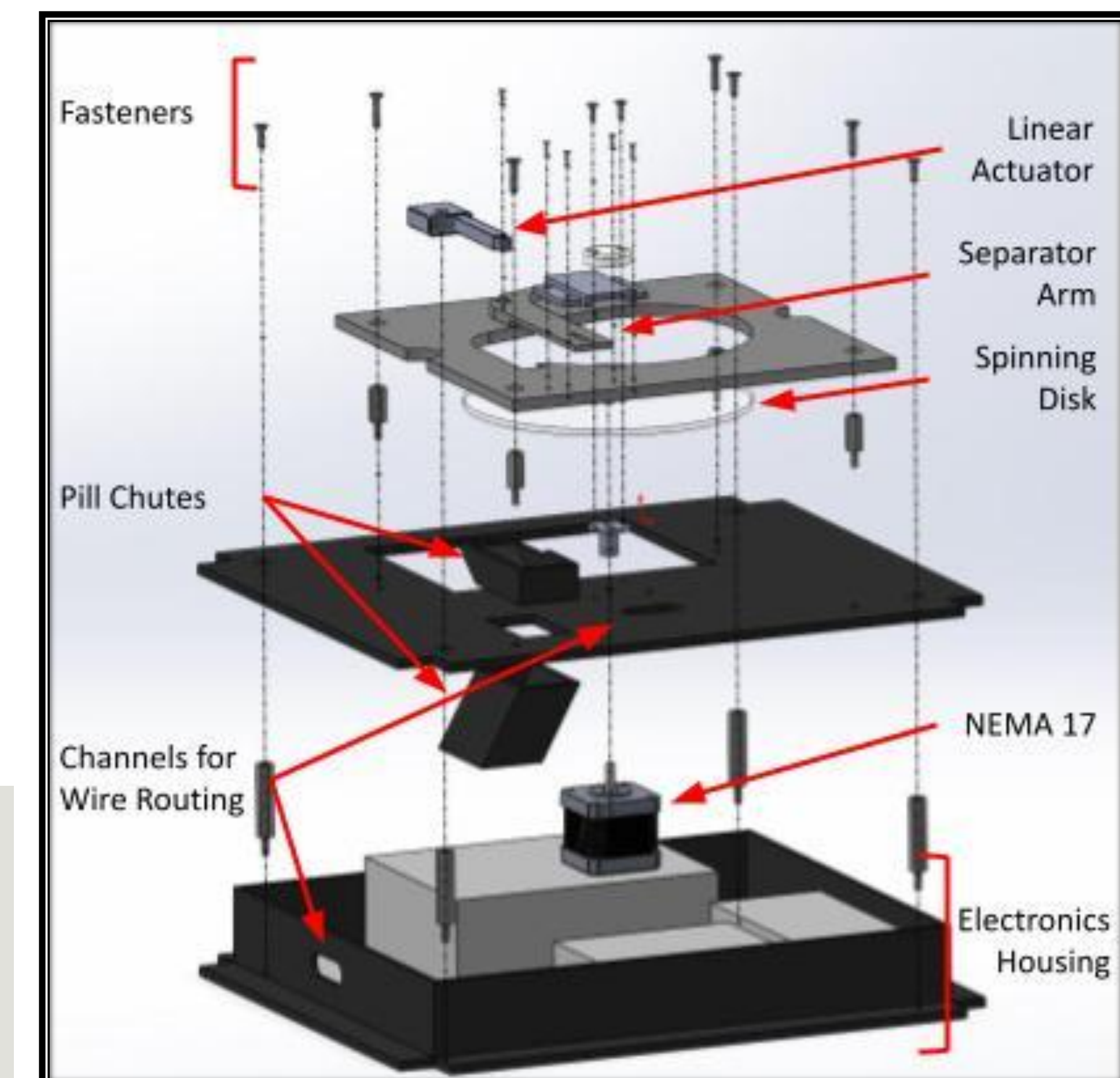
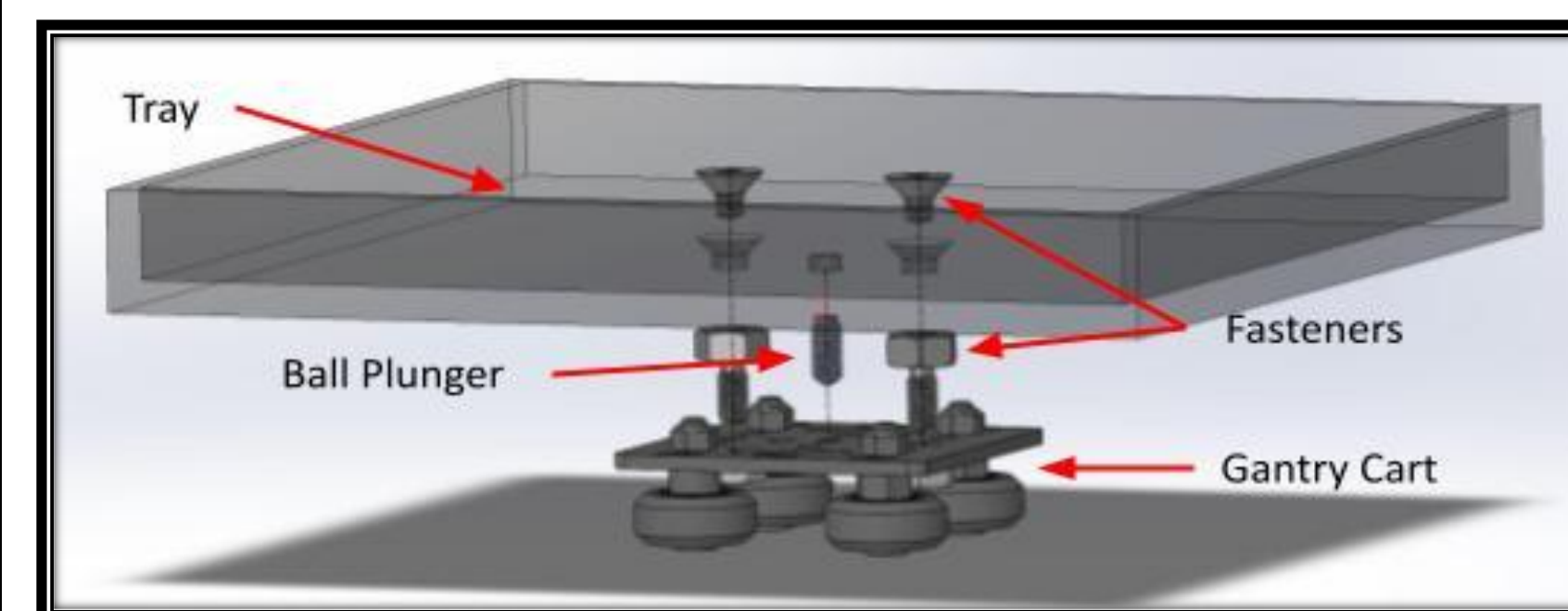
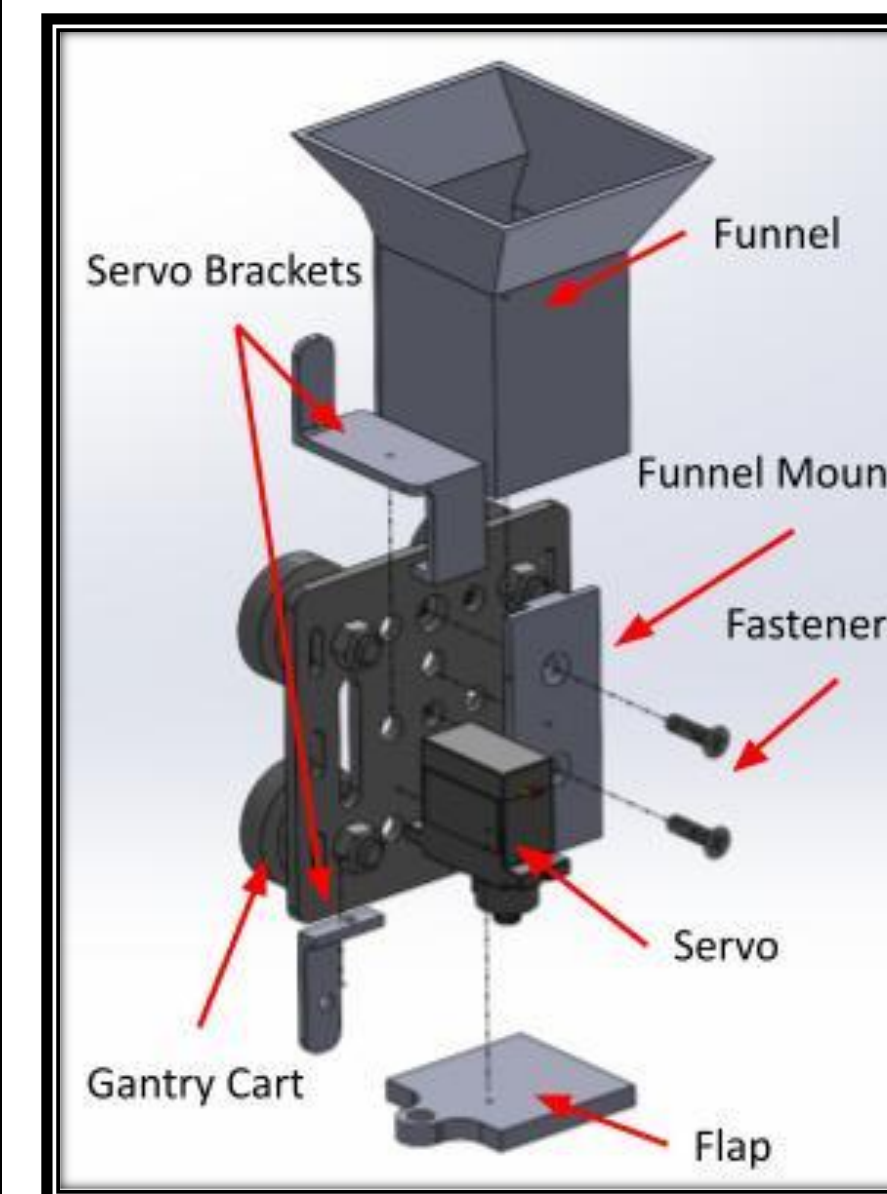
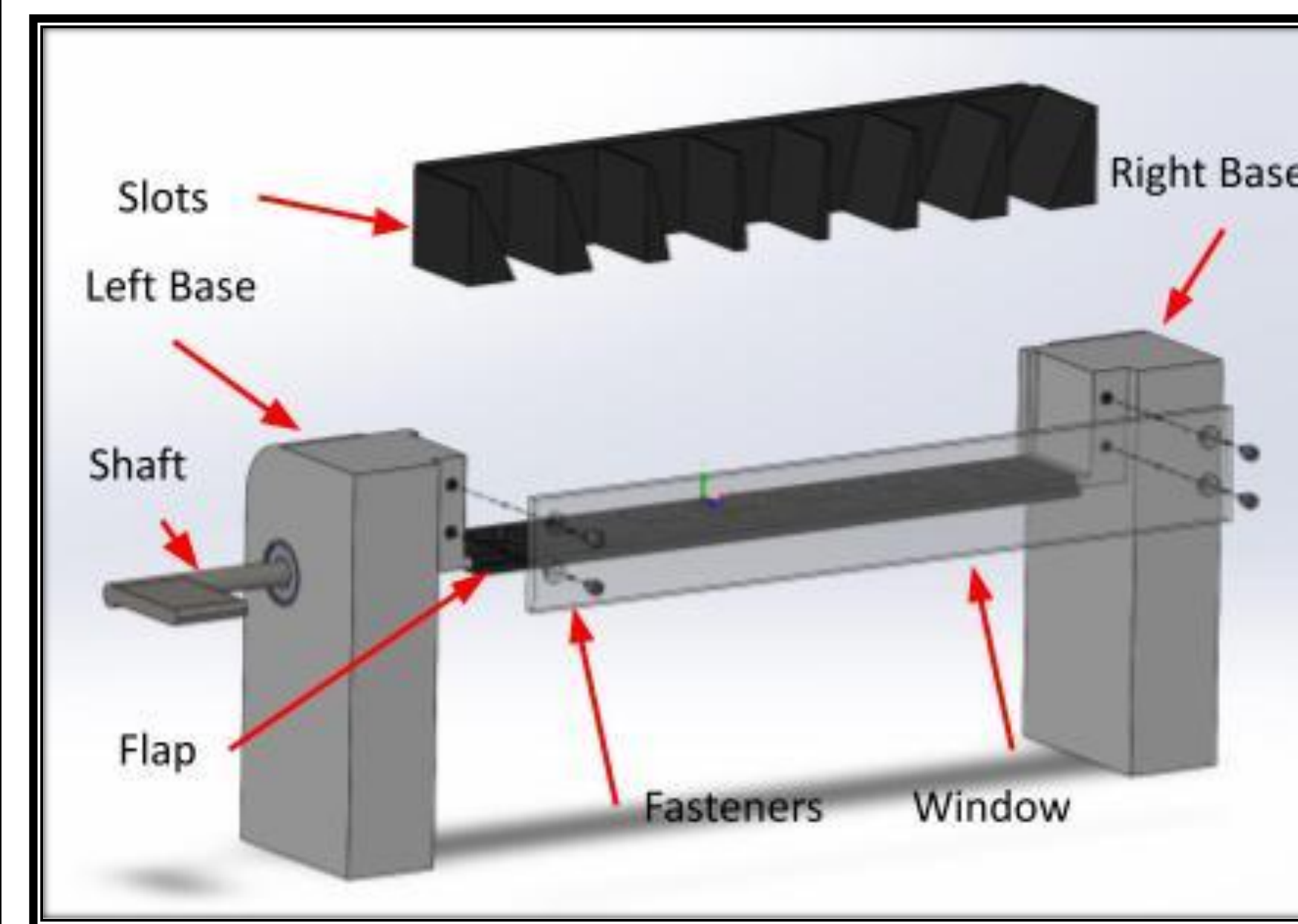

The Final Design is composed of 4 Subassemblies: Counting, Delivery, Verification, and Slider, mounted onto frame made up of linear rails. The surrounding housing is made of laser cut, acrylic panels. Transparent acrylic windows incorporate to allow for visual inspection of moving components.

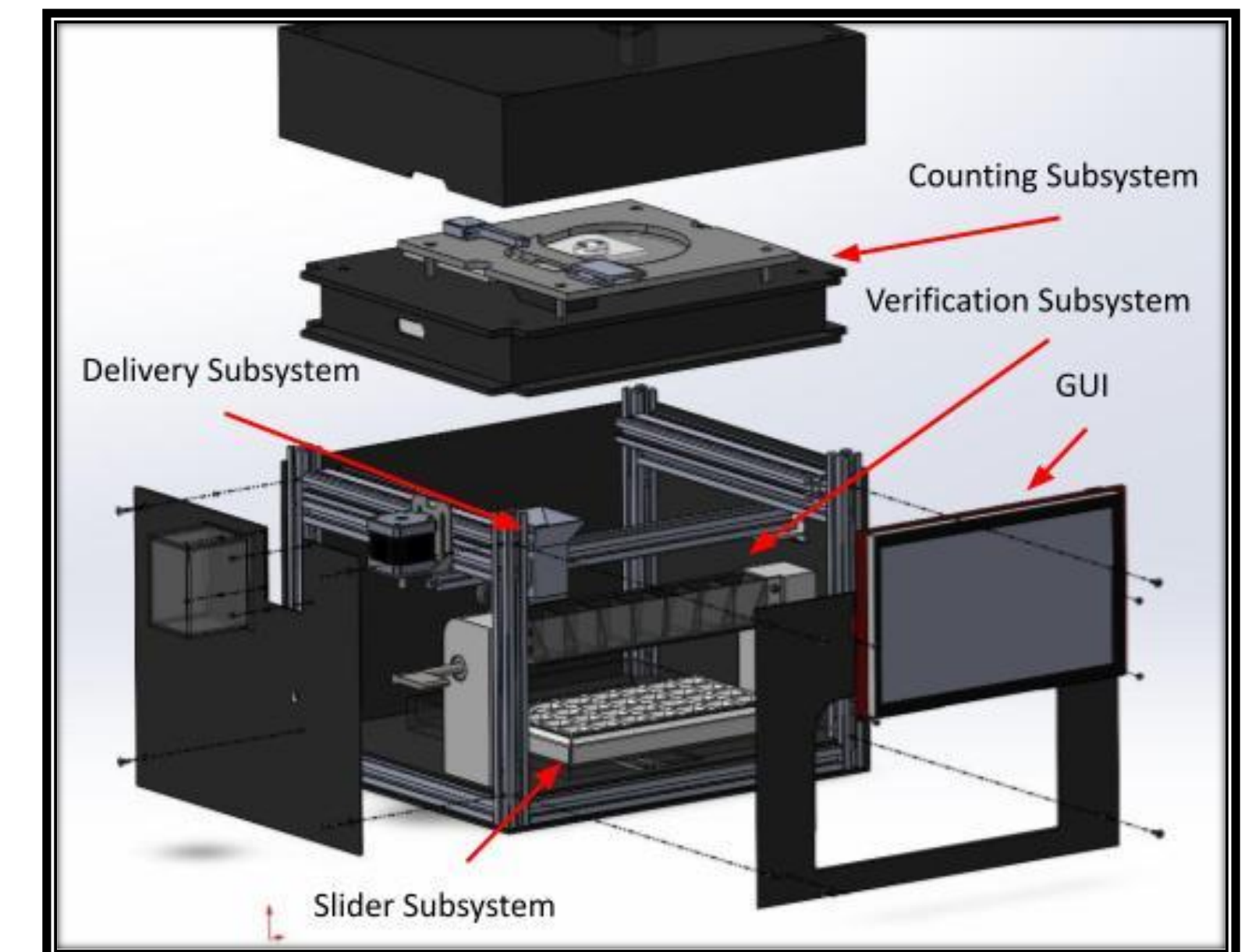

Project Overview

Quality of Life Plus (QL+) is a non-profit organization that aims to challenge University STEM students to create innovative engineering technology solutions that improve the quality of life for injured veterans, first responders, and others who have served our nation.

Quality of Life Plus has challenged Team Licensed to Pill to design and manufacture an Automated Pill Dispenser that will be used to ease the process and reduce the need for fine motor skills for patients and caregivers when placing pills into their pill organizer.

Requirements:

- Budget: \$1500
- Must be able to dispense at least 4 pills for 7 days or 1 pill for 28 days
- Must be able to accommodate various pill shapes and colors
- Must include a high-contrast, intuitive Graphical User Interface

Acknowledgments

We would like to acknowledge Dr. Scott Shaffar, Professor Barry Dorr, and Quality of Life Plus for providing guidance and support throughout the duration of this design project. Furthermore, we would like to give special thanks to Annemarie Orr, our QL+ project overseer, and Colonel Arthur Yeager, our project mentor, for their incredible insight and encouragement along the way. Lastly, we would like to acknowledge the previous teams' efforts that contributed to our final design.



Final Product

The Final Design for the Pill Dispenser is composed of the four major subsystems: Counting, Delivery, Verification, and Slider, that work together to move prescription pill doses from the top section of the dispenser to the user's personal pill organizers. The pills shall be poured into the system and the user will be prompted to inform the system of their dose specifications. The user will also need to verify and manually dispense doses weekly and shift the monthly tray to fill all four weeks of doses.

