

# Multi-Sensor Gas Flow Cell Testing Chamber

**Mechanical Engineering:** Peter Kodheli, Brayand Perez, Zachary Cartwright, Karam Alshaikh, Aaron Goldis  
**Electrical & Computer Engineering:** Christopher Westover, Kayla Hicks, Zaiver Ayarza, Andraws Yaqo, Keith Quiambao

Sponsor Advisor: Mike Frank, Ph.D.

Electrical & Computer Engineering, Mechanical Engineering Department, San Diego State University



## Objective

### Problem Statement:

AtmoSense, Inc. faces a roadblock in its quality assurance process as it can only test one sensor at a time. This bottleneck limits the company's ability to validate sensors efficiently and meet the growing demands of its customers. To overcome this challenge, team SenseTec is designing a multi-sensor gas flow cell chamber. This system will feature a sensor array that can test up to nine sensors simultaneously under controlled gas flow conditions. SenseTec's design will provide AtmoSense with a robust testing platform to test multiple sensors simultaneously, to enhance efficiency, and deliver more accurate technology to customers.

### Requirements:

1. Provide one flow cell testing chamber capable of testing up to nine sensors.
2. Provide a flow cell testing chamber that demonstrates semi-uniform gas flow distribution across all sensors.
3. Provide a user-friendly interface to monitor the changes in resistances and accurately display sensor responses.
4. Provide supporting documentation for the final cell chamber, including technical drawings, CAD models, electrical schematics, and a bill of materials.

## System Level Overview

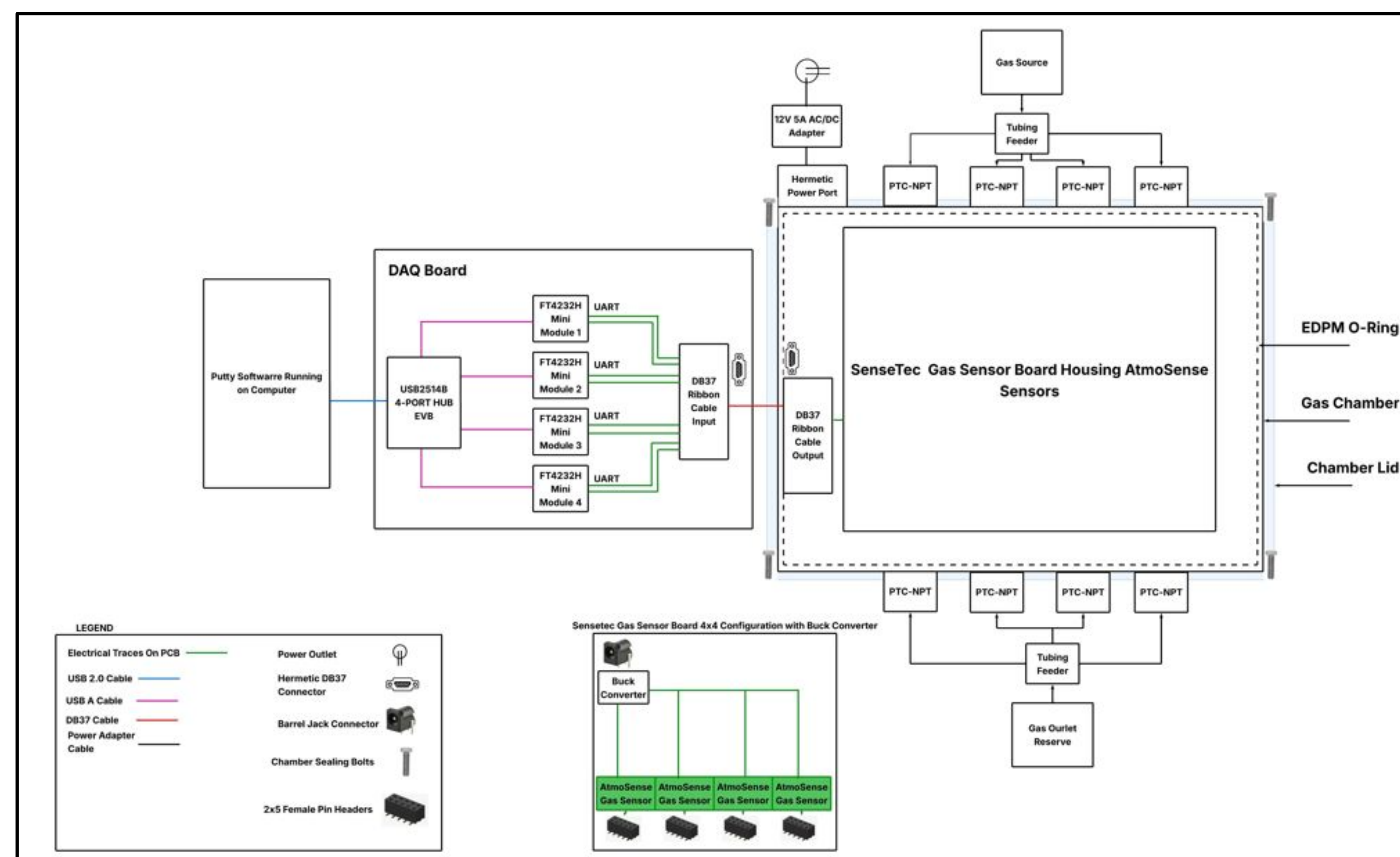

Figure 3. System-Level Diagram of the Multi-Sensor Gas Flow Cell Testing Chamber.

## Mechanical CAD Assembly

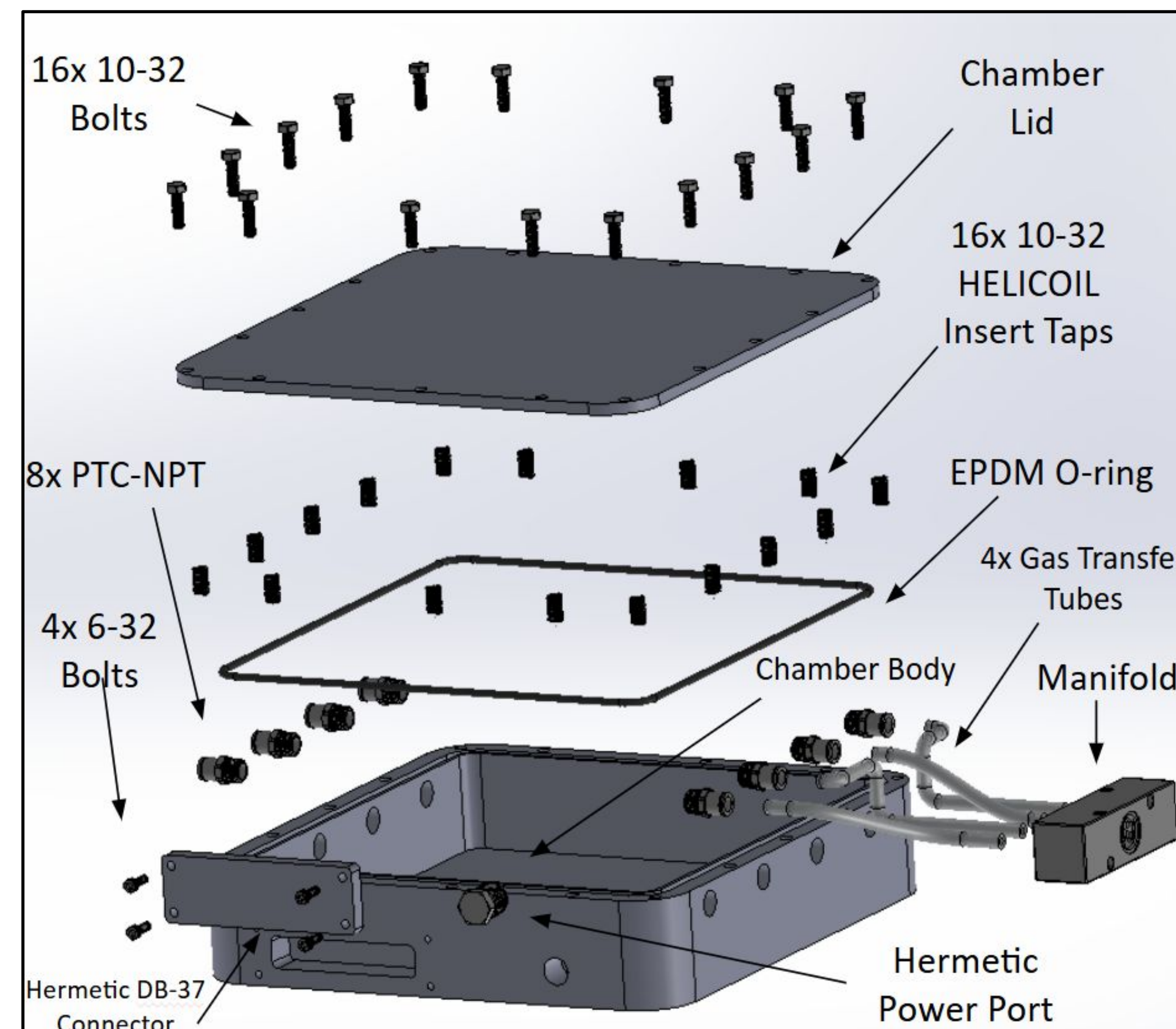

Figure 1. Exploded View of the Mechanical Assembly Created in SolidWorks.

## Chamber CFD Analysis

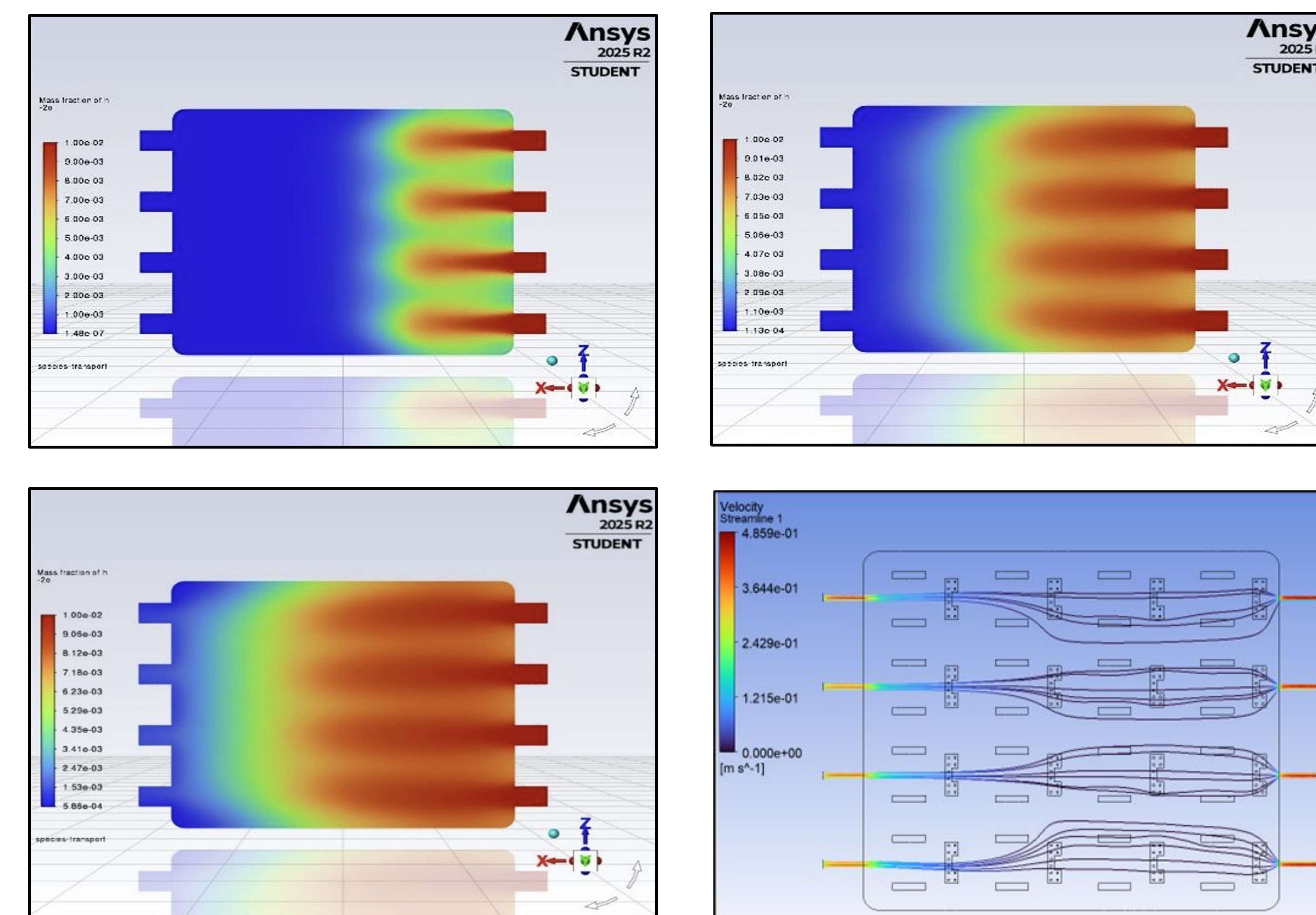

Figure 2. ANSYS Fluent CFD Results Demonstrating Velocity Contours and Streamline Behavior, Used to Verify Adequate Flow Distribution and Uniform Target Gas Dispersion Throughout the Chamber and Across the Sensor Array.

## Electrical CAD Assembly

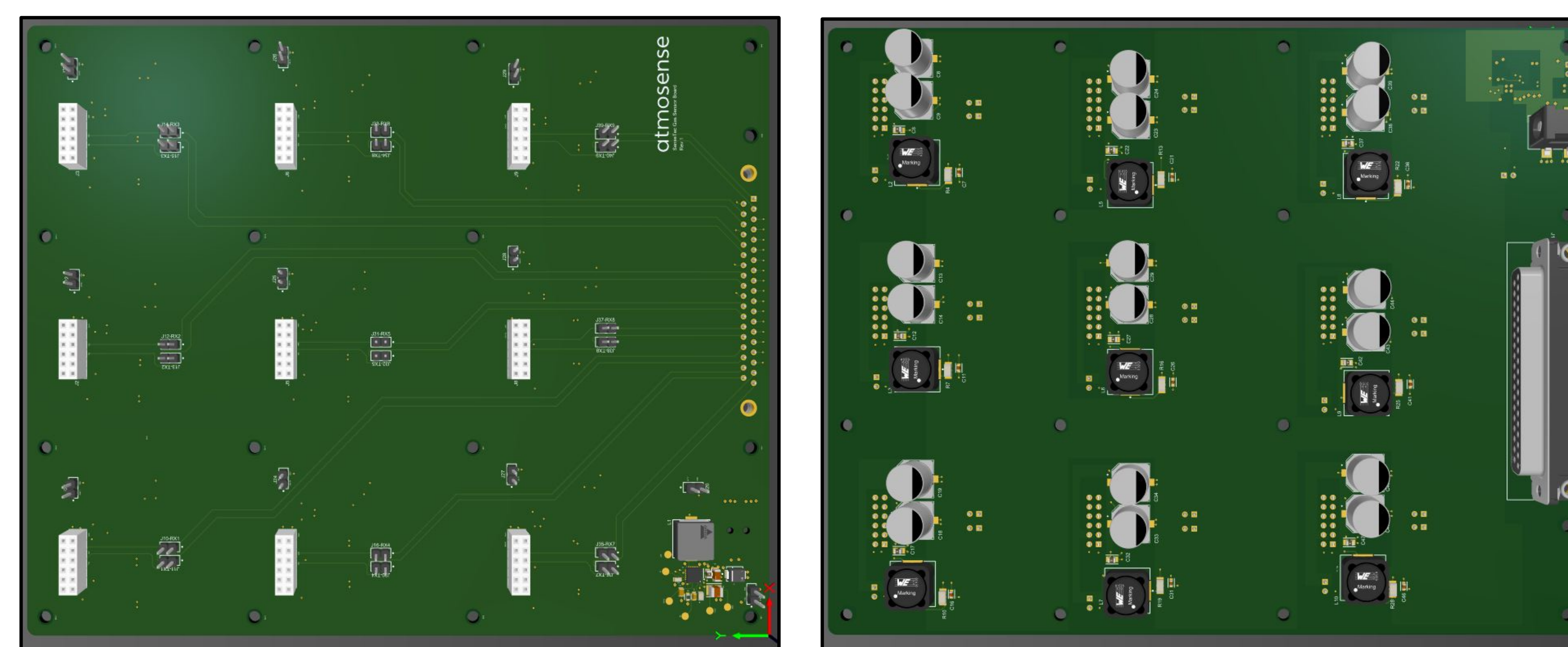

Figure 4. Top View of Gas Sensor Interface Board Designed Using Altium Designer.

Figure 5. 3D Bottom View of Gas Sensor PCB Designed Using Altium Designer.

## Electrical Testing & Analysis

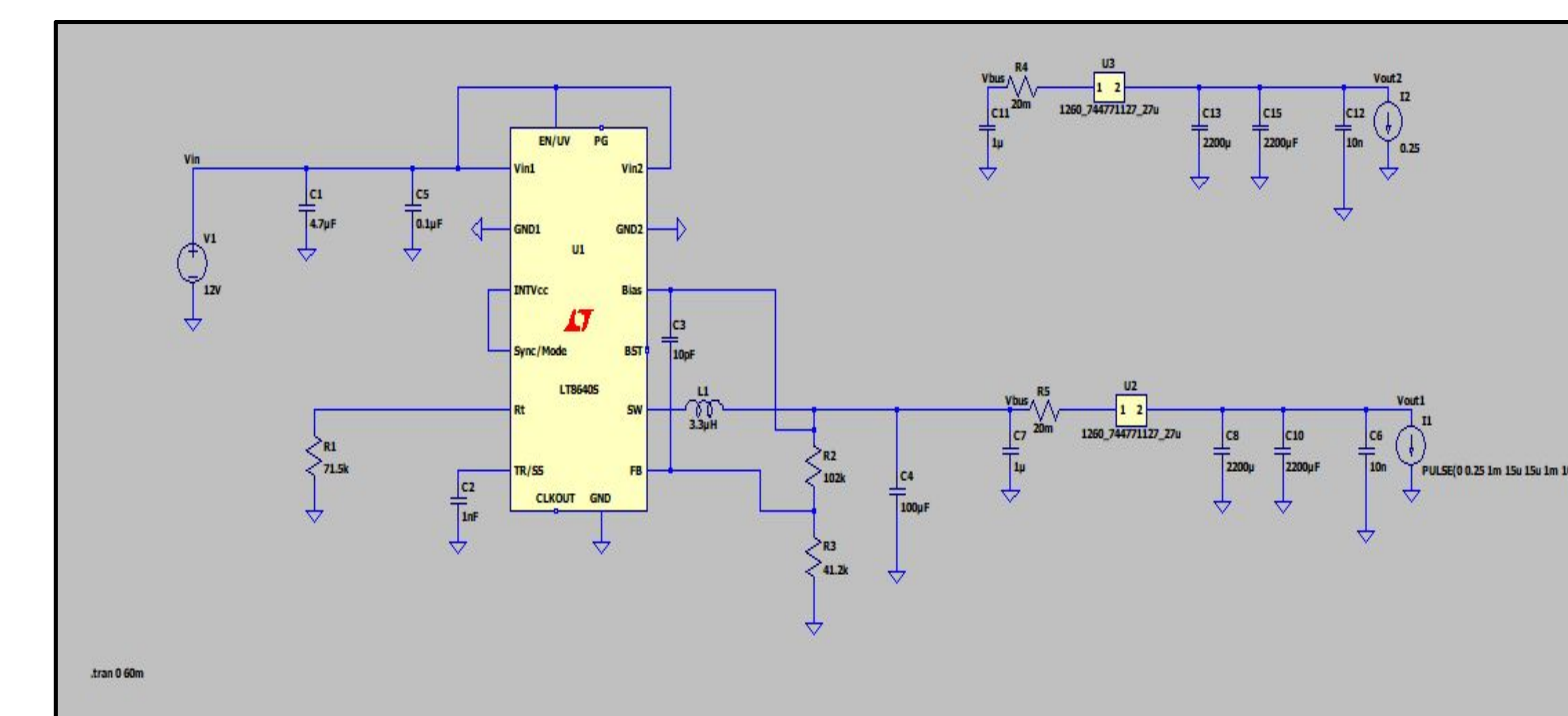

Figure 8. Buck Converter and Two-Stage Filter Design to Regulate Voltage Supply and Mitigate Noise Coupling.

## Team SenseTec Members

### Meet the Team:

#### ECE:



#### ME:

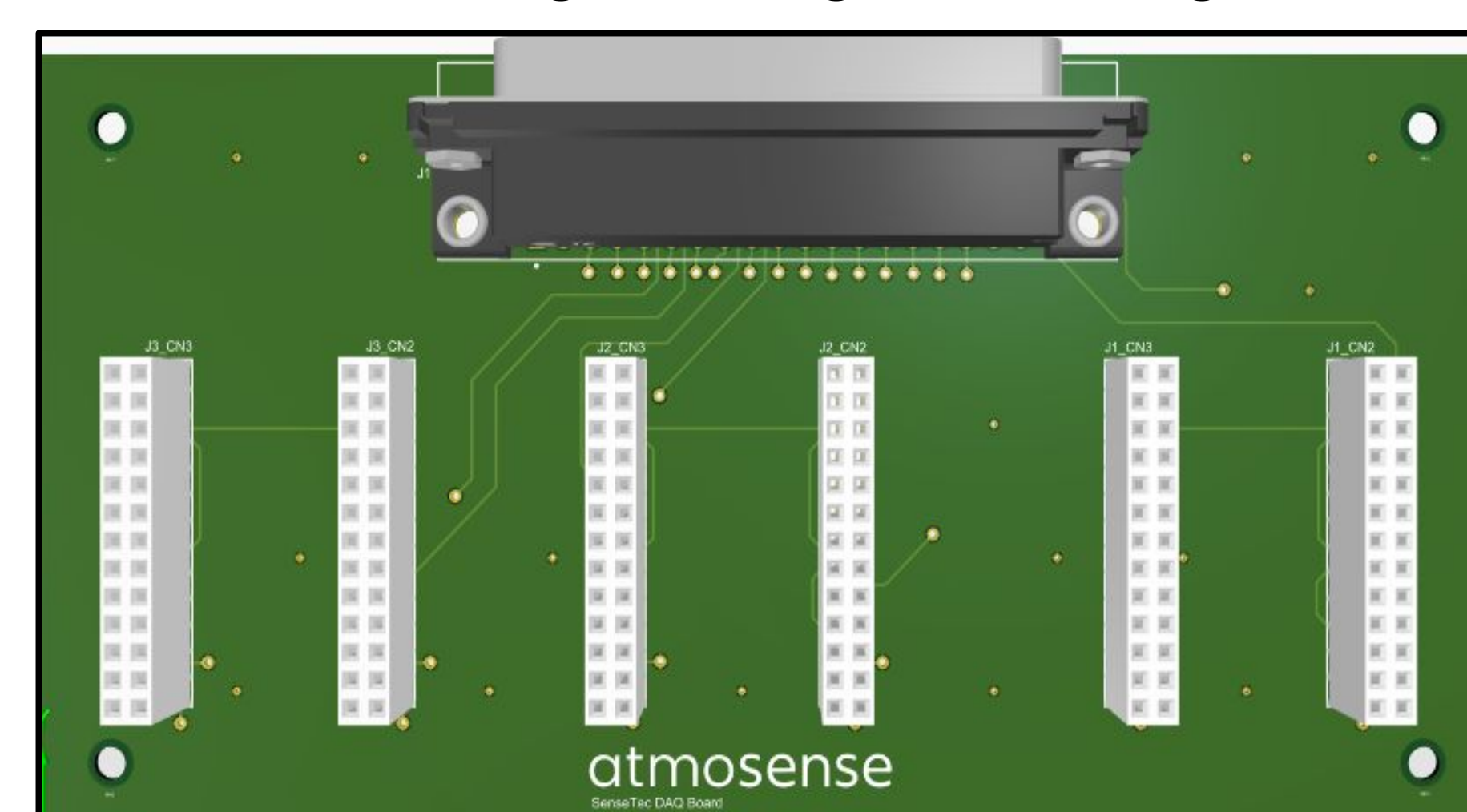

Figure 6. Top View of DAQ Board Designed Using Altium Designer.

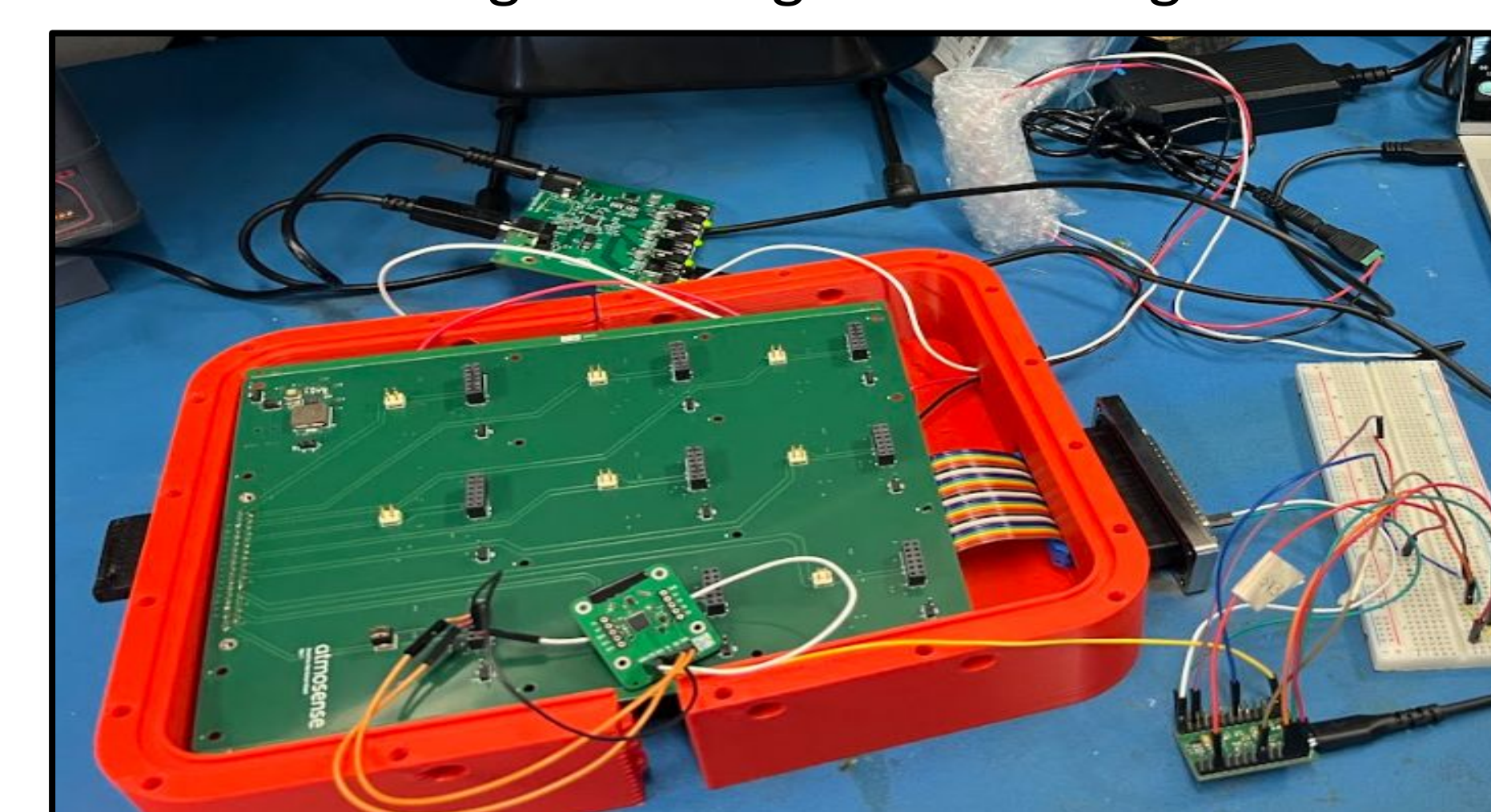

Figure 7. Gas Sensor PCB Integrated Within the 3D-Printed Enclosure for System-Level Testing and Validation.

## Acknowledgements

Team SenseTec would like to thank Dr. Scott Shaffar and the ME department for advising and procurement for this project. We would also like to thank Atmosense as a whole with special thanks to Dr. Mike Frank and Atmosense CEO Moazzem Hossain for their continued support and expertise throughout the project. Special thanks to Mr. Mark Bruno for his support with troubleshooting in the Senior Design Lab.