

Team: **synclink**



David Jazo
Team Lead



Albert Shamoun
Mechanical Integration



Sonny Shin
Manufacturing



Joseph Sagmani
Mechanical Design



Fouad Sabeeh
FEA



Shomrick Bhadra
Controls & Power Systems



Scott Melton
ECE Integration Lead



Ava Halkola
Signal Processing & Instrumentation



Christi Saengsavang
Automation Systems

About the Sponsor

General Dynamics Ordnance and Tactical Systems (GD-OTS) is a global aerospace and defense company dedicated to equipping the U.S. military and its allies with a comprehensive suite of weapons and platform solutions, including armaments, missile subsystems, motion control, munitions, energetics, protection systems and composite aerospace structures for land, sea and air applications

Overview

Problem: Current synchro testing at GD OTS is done manually, requiring technicians to physically move the input shaft to capture mechanical and electrical angles. This creates ergonomic risk and results in longer test cycles, reducing production efficiency.

Requirements: An autonomous tabletop system is needed to move the synchro output shaft to a specified degree, capture the electrical angle, and calculate the angular error between both measurements. The system must plug into a standard outlet, be programmed in LabView, and be validated through a Gauge R&R study

Manufacturing & Integration

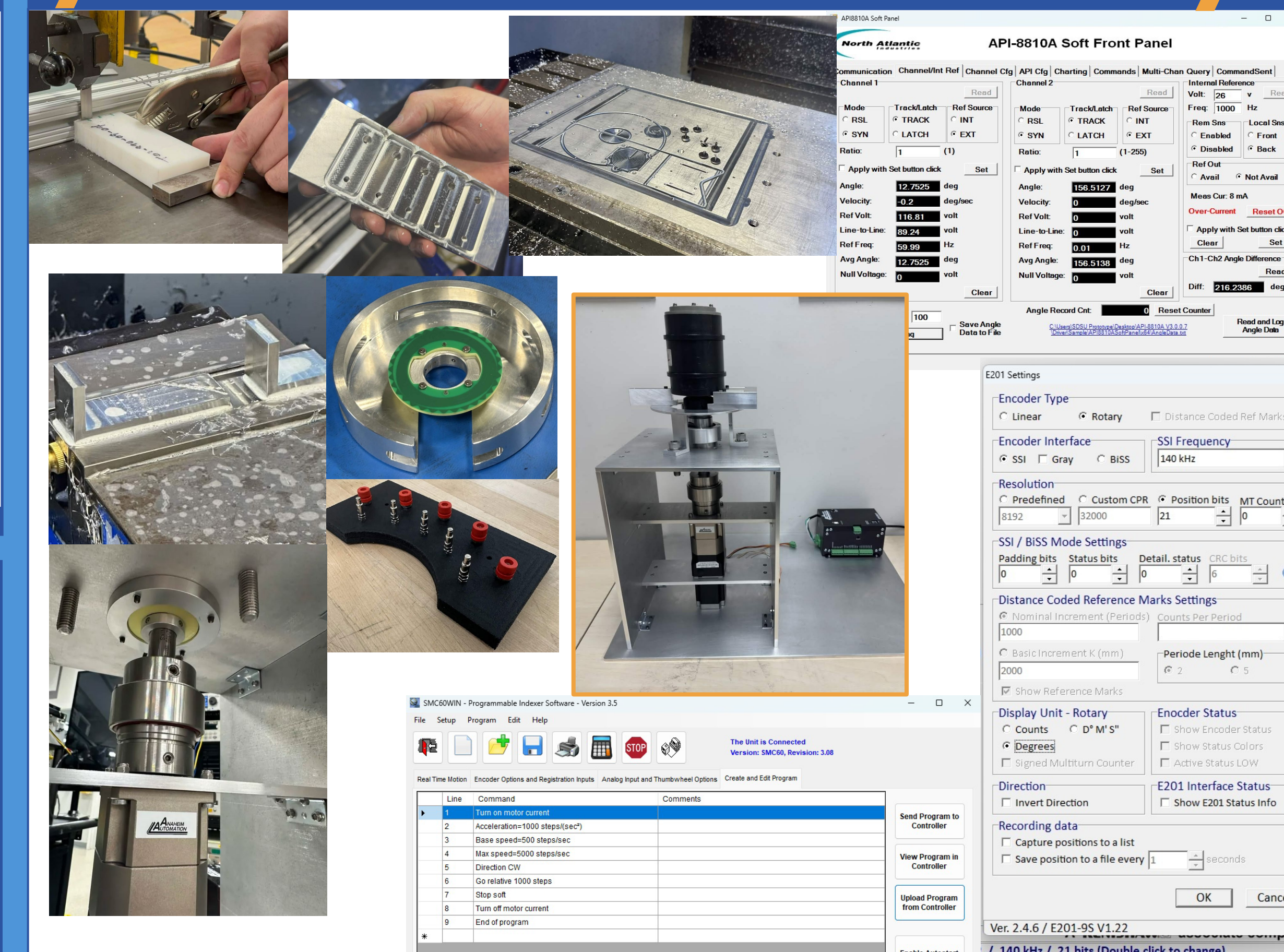

Design

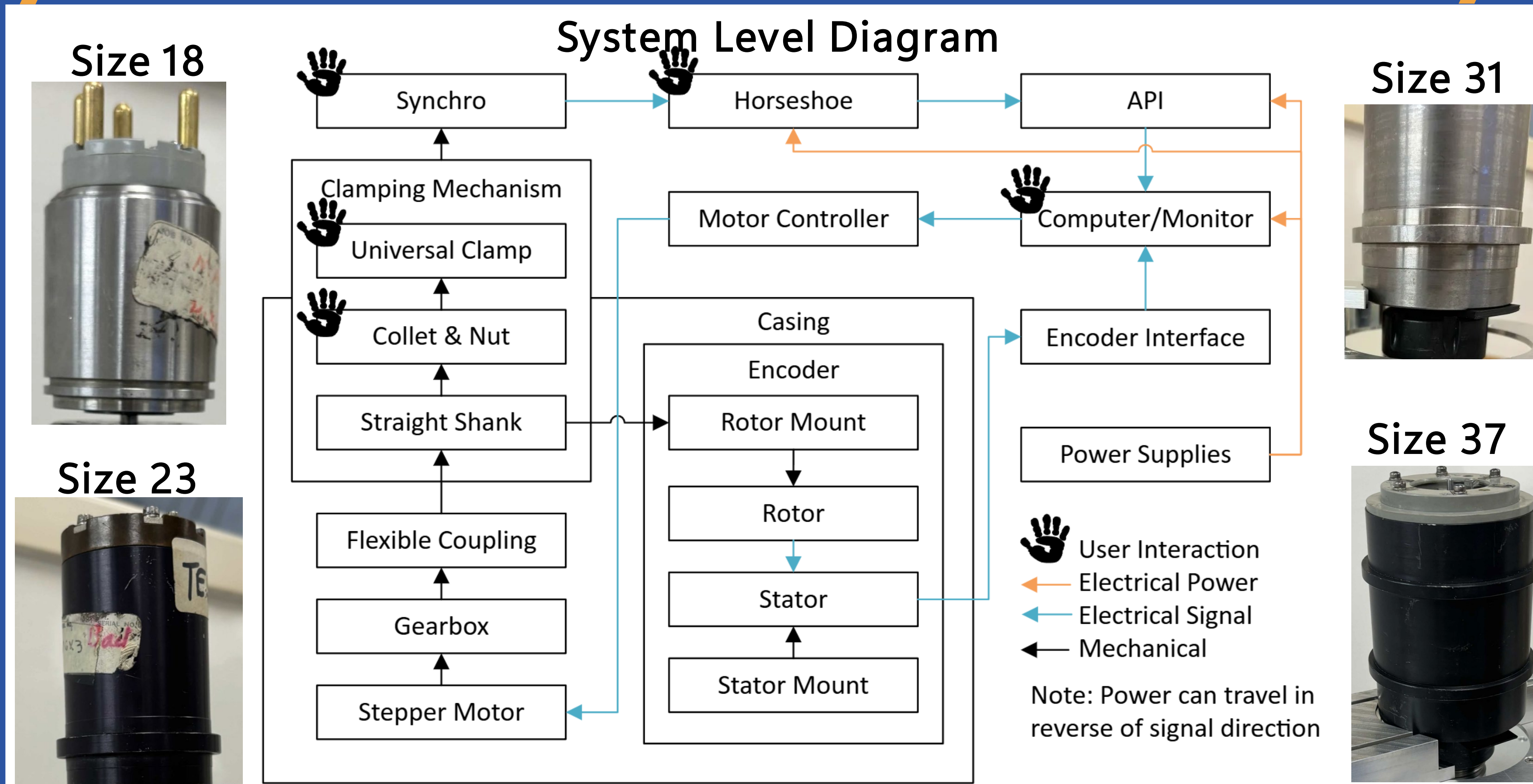

Testing & Analysis

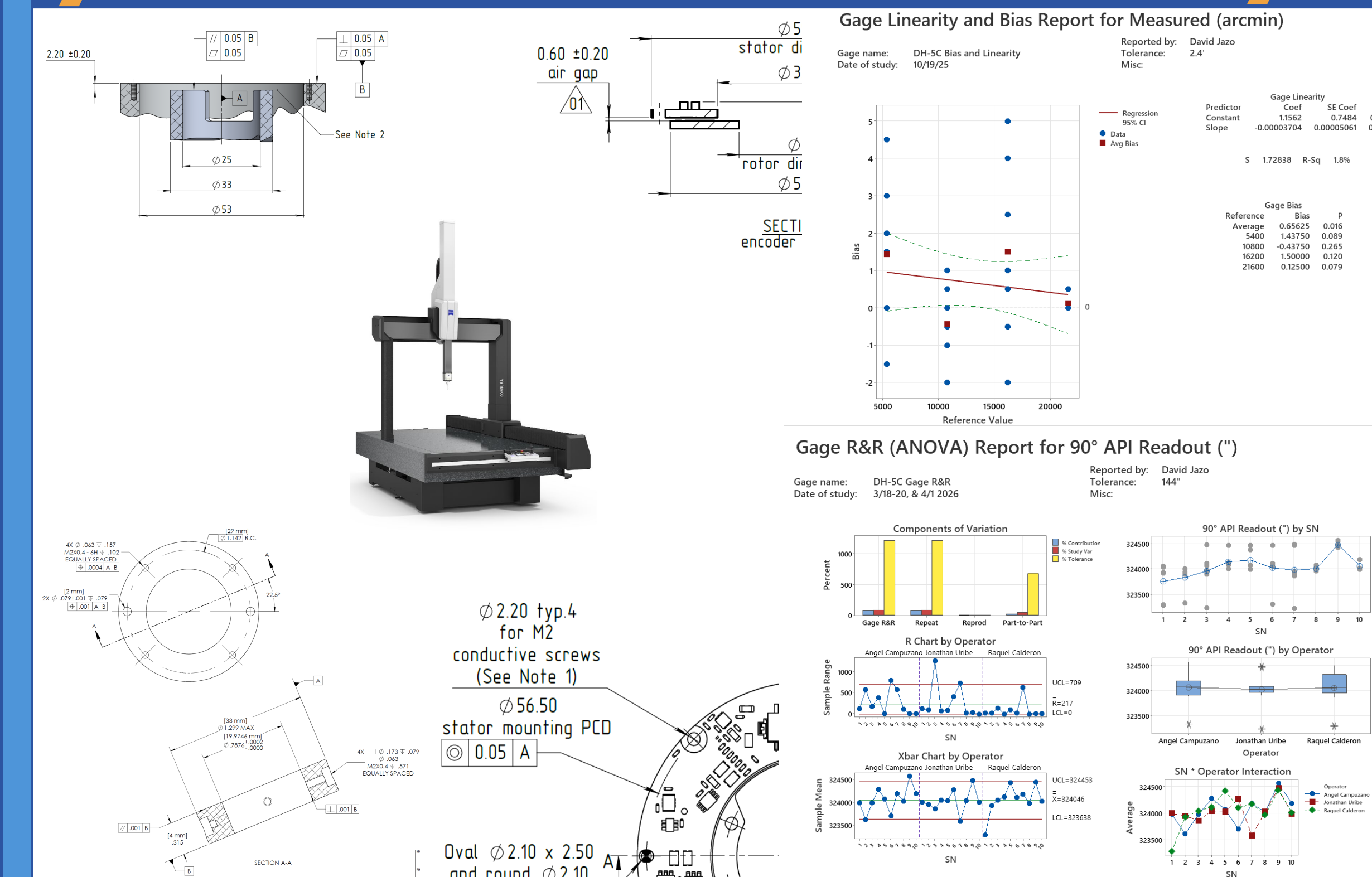

Acknowledgments

Team Synclink would like to send a special thank you to the following people that have aided this project:

General Dynamics OTS: Adrian Aldaco, Keith Onstott, Brandon Pelham, Kurt Helmlinger, David Brude, Carlos Guerra

San Diego State University: Dr. Scott Shaffar, Dr. Christopher Paolini, Dominic Malanga, Jessica Munoz, Aidan Kiswoto